

CGR17500: Cylindrical Model

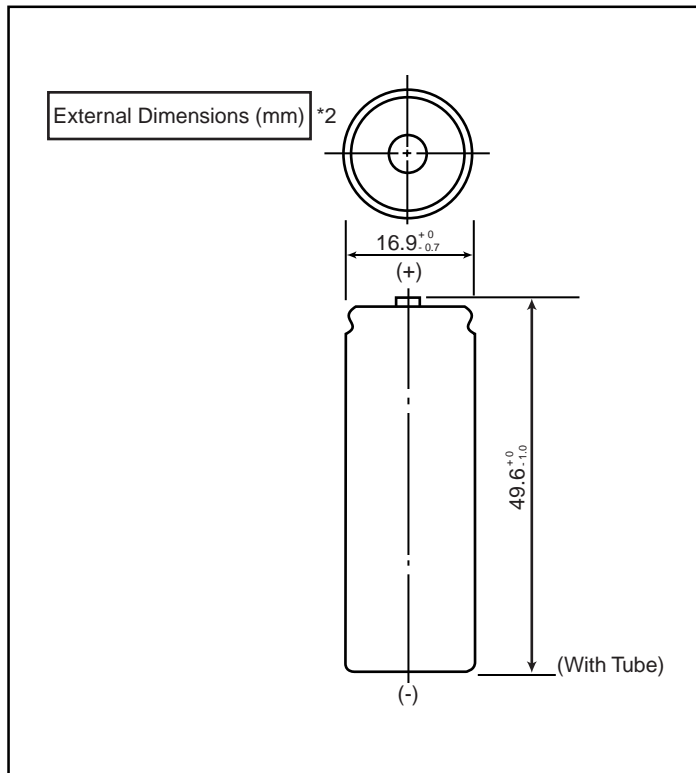

Specifications

Nominal Voltage		3.6V
Standard Capacity *1		830mAh
Dimensions*2	Diameter	16.9 +0/-0.7mm
	Height	49.6 +0/-1.0mm
	Weight	Approx. 25g

*1 After a fresh battery has been charged at constant voltage/constant current (4.2 V, 550 mA (max), 2 hours, 20°C), the average of the capacity (ending voltage of 3 V at 20°C) that is discharged at a standard current (156 mA).

*2 Dimensions of a fresh battery

Discharge Characteristics

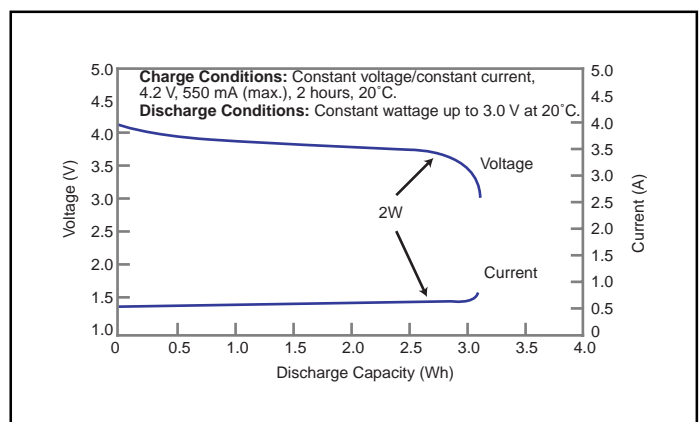
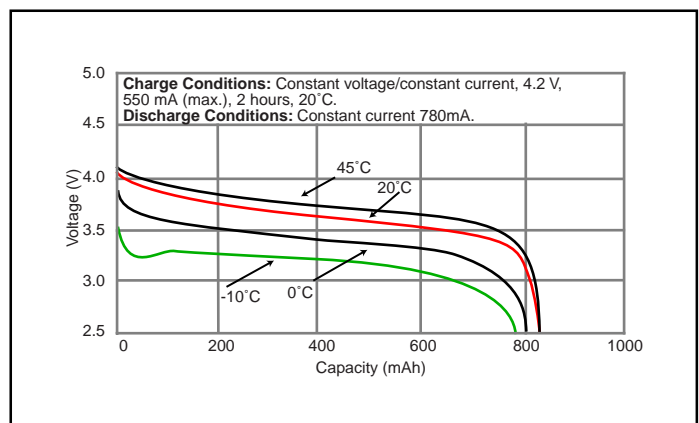
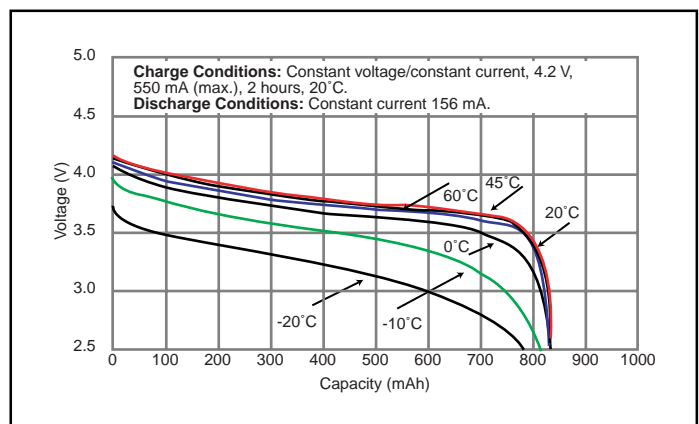
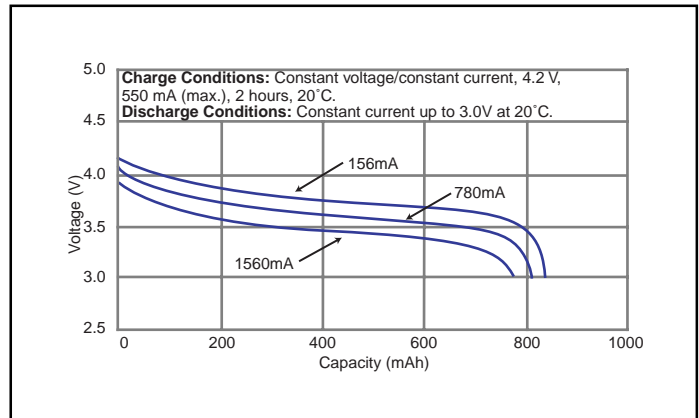

Discharge Characteristics

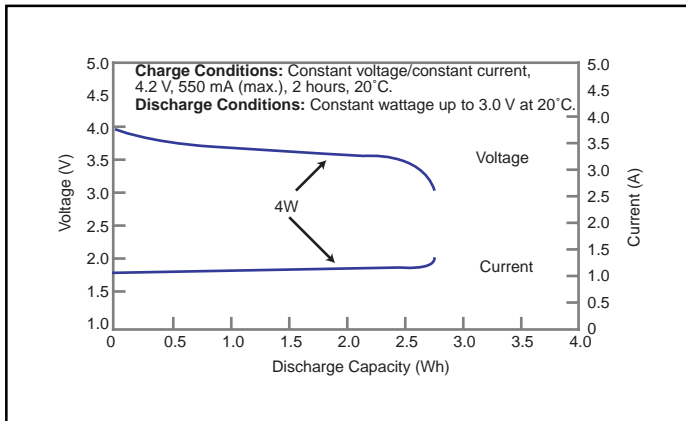

Storage Characteristics

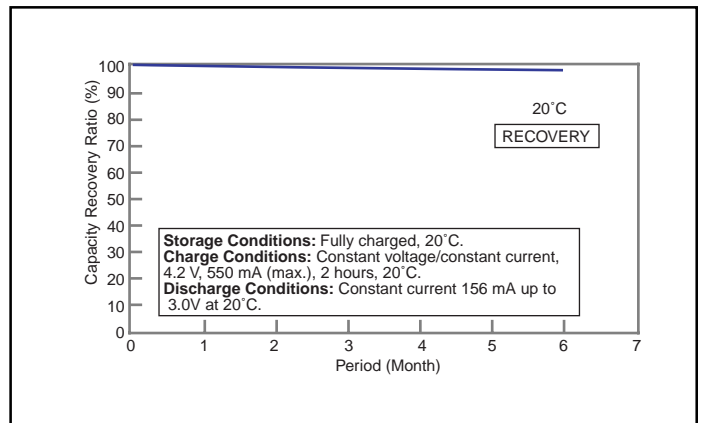
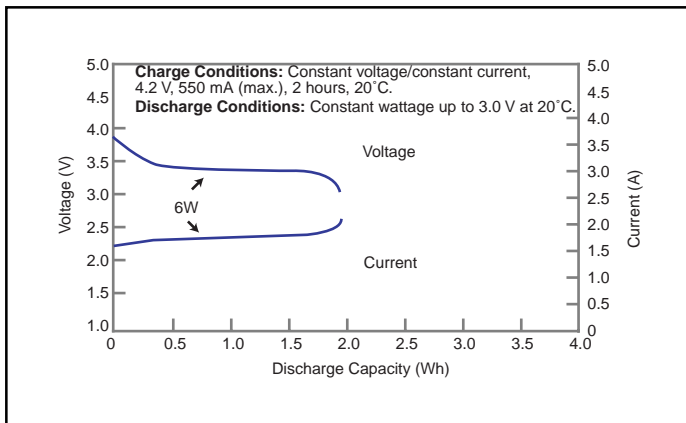
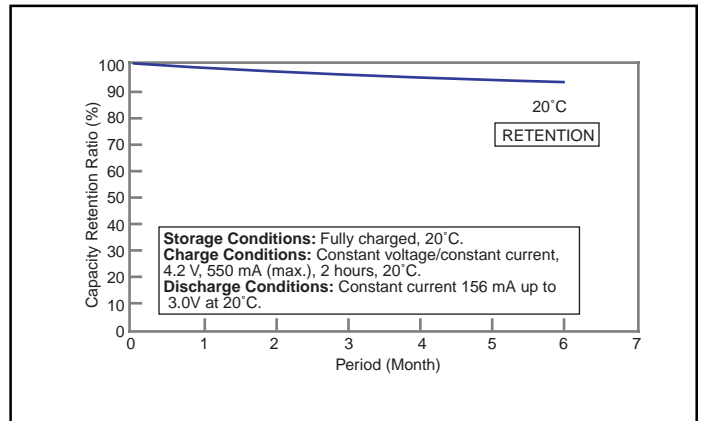

Charge Characteristics

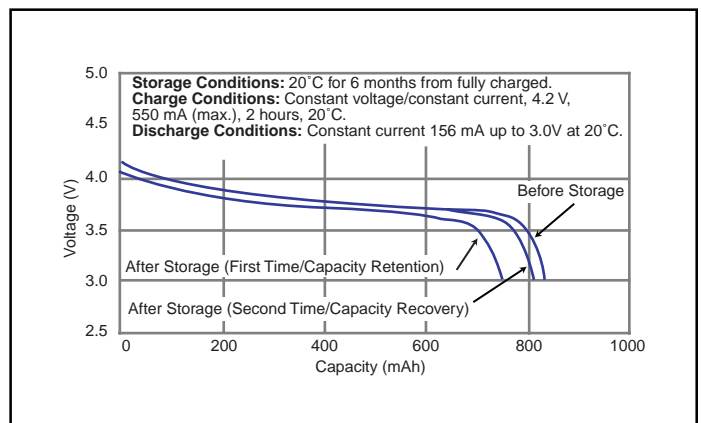
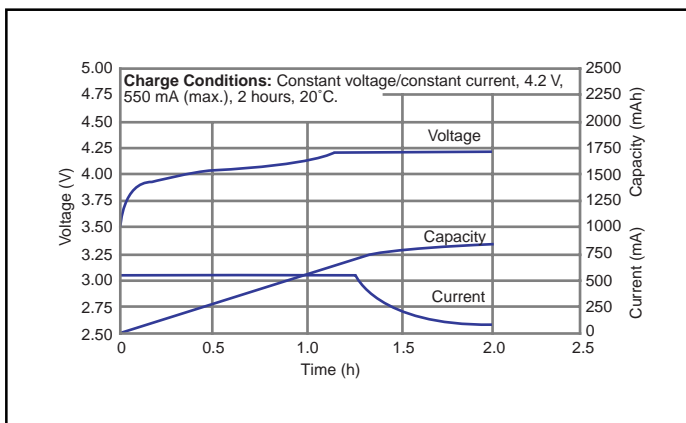

Cycle Life Characteristics

