

AA Portable Power Corp.

Document Number:

Revision: 3

Document Title: Product Specification of Ni-MH D 10000 Cells

Page 1 of 3

1、SCOPE

This specification governs the performance of the following Nickel-Metal hydride Cylindrical cell and its stack-up battery.

Model: MH- D10000B

Cell Size: D Flat Top ($\phi 32.1^{+0.2} \times 60.0^{+0.5}$)

2 、 DATA OF STACK UP BATTERIES

All data involves voltage and weight to stack-up battery are equal to the value of unit cell time the number of unit cell which consisted in the stack-up batteries

Example : Stack-up batteries consisting three unit cells

Nominal voltage of unit cell=1.2V

Nominal voltage of stack-up batteries =1.2V×3=3.6V

3、 RATINGS

Description	Unit	Specification	Conditions
Nominal Voltage	V/Cell	1.2	Unit cell
Nominal Capacity	mAh	10000	Standard Charge/Discharge
Standard Charge	mA	1000(0.1C)	T ₁ =0~45°C (see Note1)
	Hour	14~16	
Quick Charge	mA	3000 (0.3C)	- Δ V=0~5mV/cell or Timer Cutoff=120% nominal capacity or Temp.Cutoff=55°C, T ₁ =10~45°C
	Hour	4.0approx (see Note 2)	
Trickle Charge	mA	(0.05C)~(0.1C)	T ₁ =0~45°C
Standard discharge	mA	2000 (0.2C)	T ₁ = -30~60°C Humidity: Max.85%
Discharge Cut-off Voltage	V/cell	1.0	
Storage Temperature	°C	-30~65	Discharged state、 Humidity、 Max.85%
Typical Weight	Gram	165	Unit cell

AA Portable Power Corp.

Document Number:

Revision 3

Document Title: Product Specification of Ni-MH D 10000 Cells

Page 2 of 3

4、 PERFORMANCE

Unless otherwise stated, tests should be done within one month of delivery under the following conditions:

Ambient Temperature : $20 \pm 5^{\circ}\text{C}$

Relative Humidity : $65 \pm 20\%$

Notes: Standard Charge/Discharge Conditions:

Charge: 1000 mA(0.1C)×14 hours

Discharge: 2000 mA(0.2C) to 1.0V/cell

Test	Unit	Specification	Conditions	Remarks
Capacity	mAh	≥ 1000	Standard Charge Discharge	up to 3 cycles are allowed
Open Circuit Voltage(OCV)	V/cell	≥ 1.25	Within 1 hour after standard Charge	
Internal Impedance	mΩ /cell	≤ 7.0	Upon fully charge(1KHz)	
High Rate Discharge(1C)	minute	≥ 54	Standard Charge, 1 hour rest Before discharge by 10000mA (1C)to 1.0V/cell	up to 3 cycles are allowed
Overcharge	/	No leakage nor explosion	850mA(0.1C)Charge 28 days	
Charge Retention	mAh	$\geq 5950(70\%)$	Standard Charge, Storage: 28 days, Standard Discharge	
IEC Cycle Life	Cycle	≥ 500	IEC285(1993)4.4.1	(see Note 3)
Accelerated Cycle Life	Cycle	≥ 400	Charge:2550mA(0.3C) Discharge: 42500mA(0.5C) To 1.0V/cell, End-of:80% nominal Capacity	Cycling charging cut-off condition: - $\Delta V=0\sim 5\text{mV/cell}$ and Timer cut-off=110% Nominal capacity Input and Temp.cutoff= 55°C
Leakage		No leakage nor deformation	Fully charged at 0.3C for 4.0 hrs Stand for 14 days	
Vibration Resistance		Change of voltage should be under 0.02V/cell,Change of impedance should be under 5 milli-ohm/cell	Charge the battery 0.1C 14hrs,then leave for 24hrs,check battery before/after vibration, amplitude 1.5mm Vibration 3000 CPM Any direction for 60mins.	
Impact Resistance		Change of voltage sho-uld be under 0.02V/cell Change of impedance should be under 5 milli-ohm/cell	Charge the battery 0.1C 14hrs Then leave for 24hrs,check bat-before/after dropped, Height 50cm Wooden board(thickness 30mm) Direction not specified,3 times.	

AA Portable Power Corp.

Document Number:

Revision: 3

Document Title: Product Specification of Ni-MH D10000 Cells

Page 3 of 3

5、CONFIGURATION, DIMENSIONS AND MARKINGS

Please refer to the attached drawing.

6、EXTERNAL APPEARANCE

The cell/battery shall be free from cracks, scars, breakage, rust, discoloration, leakage nor deformation.

7、WARRANTY

3months limited warranty against workmanship and material defects.

8、CAUTION

- (1)Reverse charging is not acceptable.
- (2)Charge before use. The cells/batteries are delivered in an uncharged state.
- (3)Do not charge/discharge with more than our specified current.
- (4)Do not short circuit the cell/battery Permanent damage to the cell/battery may result.
- (5)Do not incinerate or mutilate the cell/battery.
- (6)Do not solder directly to the cell/battery.
- (7)the life expectancy may be reduced if the cell/battery is subjected adverse conditions like: extreme temperature, deep cycling, excessive overcharge/ over-discharge.
- (8)store the cell/battery uncharged in a cool dry place. Always discharge batteries before bulk storage or shipment.

Notes:

- (1) T_1 : Ambient Temperature.
- (2) Approximate charge time from discharged state, for reference only.
- (3) IEC285(1993)4.4.1 Cycle Life:

Cycle No.	Charge	Rest	Discharge
1	$0.1C \times 16h$	None	$0.25C \times 2h20min$
2-48	$0.25C \times 3h10min$	None	$0.25C \times 2h20min$
49	$0.25C \times 3h10min$	None	$0.25C$ to $1.0V/cell$
50	$0.1C \times 16h$	1-4h	$0.2C$ to $1.0V/cell$
Cycles 1 to so shall be repeated until the discharge duration on any 50th Cycle becomes less than 3 h.			

AA Portable Power Corp.

MODEL No: MH-D10000B

Description: 10000mAh D SIZE NI-MH

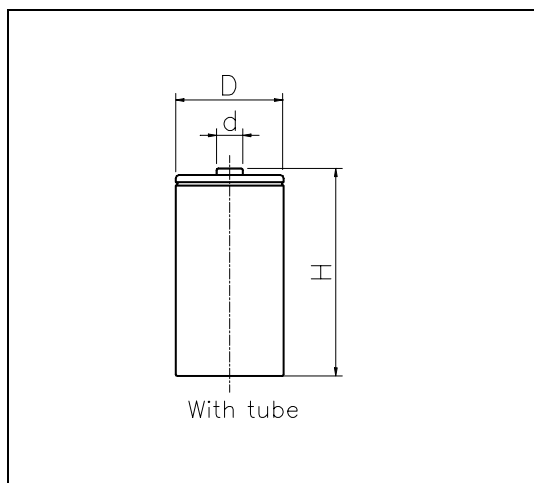

Dimension of the cell

D	$\Phi 32.1 \pm 0.2$
d	$\Phi 8.0 \pm 0.05$
H	60.5 ± 0.5

Specification

Nominal Capacity 额定容量	10000 mAh		
Nominal Voltage 额定电压	1.2 V		
Charge current 充电电流	Standard 标准	1000mA	
	Quick 快充	3000 mA	
Charge time 充电时间	Standard 标准	14~16 Hrs	
	Quick 快充	4.0 Hrs	
Ambient Temperature 使用温度	Charge 充电	Standard 标准	0°C~45°C
		Quick 快充	10°C~45°C
	Discharge 放电		-30°C~60°C
	Storage 储存		-30°C~65°C
Internal Impedance(mΩ) (After Charge) 充电后内阻		Max ≤7.0	
Weight 重量		164g	

Charge(充电)

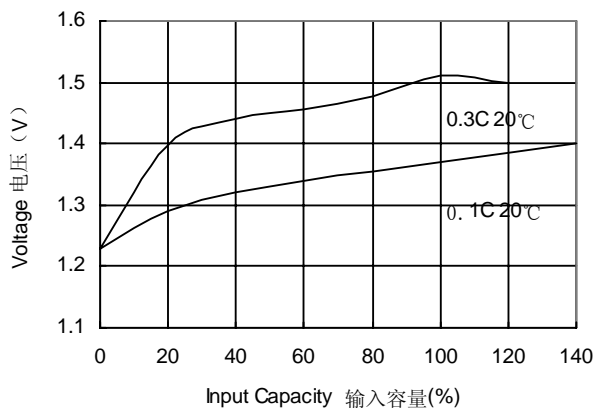

Discharge at high rate(高倍率放电)

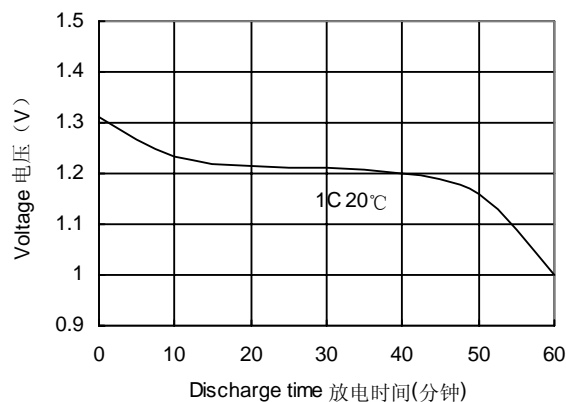

Discharge at low rate(低倍率放电)

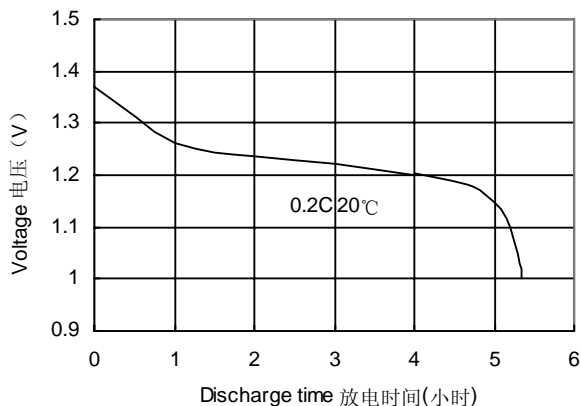

Charge Retention(荷电保持能力)

