

1. This product specification describes polymer LiFePO₄ battery. Please use the test methods that recommend in this specification. If you have any opinions or advices about the test items and methods, please contact us. Please read the cautions recommended in the specifications first, take the credibility measure of the cell's using.

If the cells should be using at the environment that not preferred in this document, please contact us first and get our authorization. For the reason of stable Performance and better safety, battery pack with more than 2 cells connected in serial should be charged with balance charger.

It is claimed that we should have no any responsibility with the contingency and loss due to the cells' wrong usage (not preferred in the product specification).

2. Product Type, Model and Dimension:

2.1 Type: Polymer LiFePO₄ battery

2.2 Model: 1004045L(Cell adding Cu Tabs)

2.3 Dimension (Max. T*W*L) mm: 10.2×41.0×46.5

3. Specification:

Item	Parameter	Remark
Nominal Capacity	<u>1100mAh</u> ±5%	0.2C ₅ A discharge, 25℃
Nominal Voltage	3.2V	Average Voltage at 0.2C ₅ A discharge
Standard Charge Current	0.2C ₅ A	Working temperature: 0~45℃
Max Charge Current	1.0C ₅ A	Working temperature: 0~45℃
Charge cut-off Voltage	3.80±0.05V	CC/CV
Discharge Current	Cont.3C ₅ A~Max:8C ₅ A	Working temperature: -10~60℃
Discharge cut-off Voltage	2.4V	
Cell Voltage	3.2~3.4V	When leave factory
Impedance	≤255mΩ	AC 1KHz after 50% charge,25℃
Weight	Approx:29g	
Storage Temperature	≤1month	-10~45℃
	≤3month	0~30℃
	≤12month	0~30℃
Storage humidity	65±20% RH	Best 20±5℃ for long-time storage

4. General Performance:

Definition of Standard charging method: At $20 \pm 5^\circ\text{C}$, charging the cell initially with constant current $0.2C_5A$ till voltage $3.8V$, then with constant voltage $3.8V$ till current declines to $0.05C_5A$.

Item		Test Methods	Performance
4.1	0.2C Capacity	After standard charging, laying the battery 0.5h, then discharging at $0.2C_5A$ to voltage $2.4V$, recording the discharging time.	$\geq 300\text{min}$
4.2	1.0C Capacity	After standard charging, laying the battery 0.5h, then discharging at $1C_5A$ to voltage $2.4V$, recording the discharging time.	$\geq 54\text{min}$
4.3	Cycle life	Constant current $1C_5A$ charge to $3.8V$, then constant voltage charge to current declines to $0.05C_5A$, stay 5min, constant current $1C_5A$ discharge to $2.4V$, stay 5min. Repeat above steps till continuously discharging time less than 36min.	≥ 1000 次
4.4	Capability of keeping electricity	$20 \pm 5^\circ\text{C}$, After standard charging, laying the battery 28days, discharging at $0.2C_5A$ to voltage $2.4V$, recording the discharging time.	$\geq 240\text{min}$

5. Environment Performance:

Item		Test Methods	Performance
5.1	High temperature	After standard charging, laying the battery 4h at $55^\circ\text{C} \pm 2^\circ\text{C}$, then discharging at $0.2C_5A$ to voltage $2.4V$, recording the discharging time.	$\geq 270\text{min}$
5.2	Low temperature	After standard charging, laying the battery 4h at -10°C , then discharging at $0.2C_5A$ to voltage $2.0V$, recording the discharging time.	$\geq 180\text{min}$
5.3	Constant humidity and temperature	After standard charging, laying the battery 48h at $40 \pm 2^\circ\text{C}$, RH $93 \pm 2\%$. Recording $0.2C_5A$ discharging time	$\geq 270\text{min}$. No distortion No electrolytes leakage

6. Mechanical Performance:

Item		Test Methods	Performance
6.1	Vibration	After standard charging, put battery on the vibration table. 30 min experiment from X,Y,Z axis. Scan rate: 1 oct/min; Frequency 10-30Hz, Swing 0.38mm; Frequency 30-55Hz, Swing 0.19mm.	No influence to batteries' electrical Performance and appearance.
6.2	Collision	After vibration test, batteries were laying on the vibration table about X, Y, Z axis. Max frequency acceleration: 100m/s^2 ; collision times per minutes: 40~80; frequency keeping time 16ms; all collision times 1000 ± 10 .	No influence to batteries' electrical Performance and appearance.

6.3	Drop	Random drop the battery from 1.0m height onto wood board one times.	No explosion or fire
-----	------	---	----------------------

7. Safety Test:

Test conditions: The following tests must be measured at flowing air and safety protection conditions. All batteries must standard charge and lay 24h.

Item		Test Methods	Performance
7.1	Over charge	At $20 \pm 5^\circ\text{C}$, charging batteries with constant current $3C_5A$ to voltage $5V$, then with constant voltage $5V$.	No explosion or fire
7.2	Over discharge	At $20 \pm 5^\circ\text{C}$, discharge battery with $0.2C_5A$ continuously 12.5h.	No explosion or fire
7.3	Short-circuit	At $20 \pm 5^\circ\text{C}$, connect batteries' anode and cathode by wire which impedance less than $50m\Omega$, keep 6h.	No explosion or fire
7.4	Extrusion	At $20 \pm 5^\circ\text{C}$, put the battery in two parallel steal broad, add pressure $13kN$.	No explosion or fire
7.5	Thermal shock	Put the battery in the oven. The temperature of the oven is to be raised at $5 \pm 1^\circ\text{C}$ per minute to a temperature of $130 \pm 2^\circ\text{C}$ and remains 60 minutes.	No explosion or fire

8. Cautions:

8.1 Cautions of batteries' operation:

The batteries must be careful of proceed the operation for it's soft package.

8.1.1 Aluminum packing materials:

The aluminum packing material was easily damaged by the sharp edge part, such as nickel-tabs.

- (1) Forbid to use the sharp part touching the battery;
- (2) Should cleaning working condition, avoiding the sharp edge part existence;
- (3) Forbid to pierce the battery with nail and other sharp items;
- (4) The battery was forbidden with metal, such as necklace, hairpin etc in transportation and storage.

8.1.2 Sealed edge:

- (1) Sealing edge is very easily damaged and don't bend it.
- (2) The Al interlayer of package has good electric Performance. It's forbidden to connect with exterior component for preventing short-circuits. (Short the anode and the Al interlayer of package will cause corrosion or swollen of the cell).

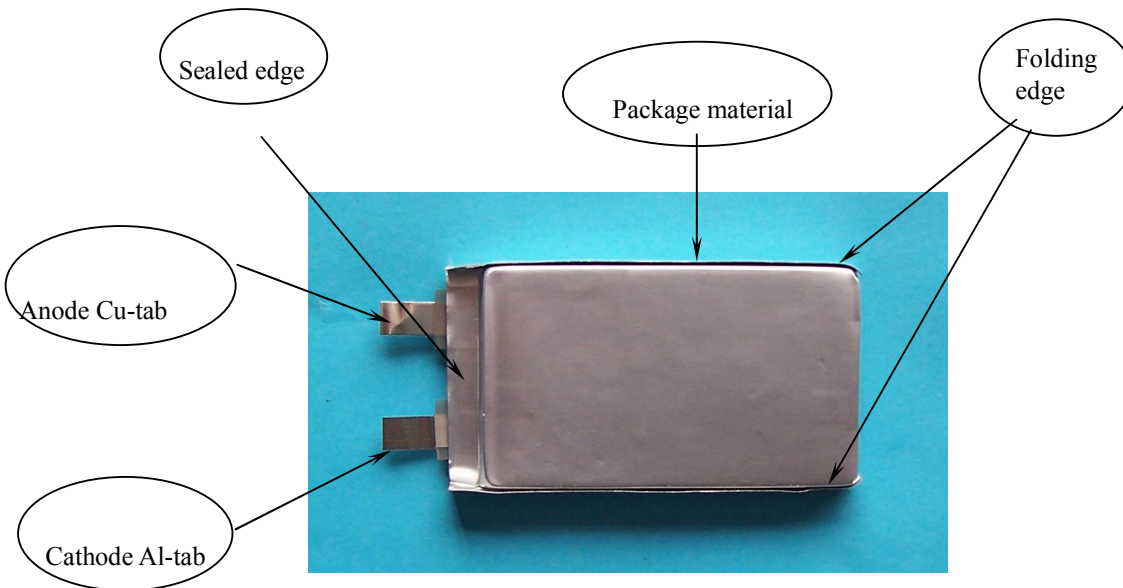

Pic 1: Exterior schematic of polymer LiFePO4 cells

8.1.3

Folding edge:

- (1) The folding edge is formed in batteries' processes and passed all hermetic tests, don't open or deform it.
- (2) The Al interlayer of package has good electric Performance. It's forbidden to connect with exterior component for preventing short-circuits. (Short the anode and the Al interlayer of package will cause corrosion or swollen of the cell).

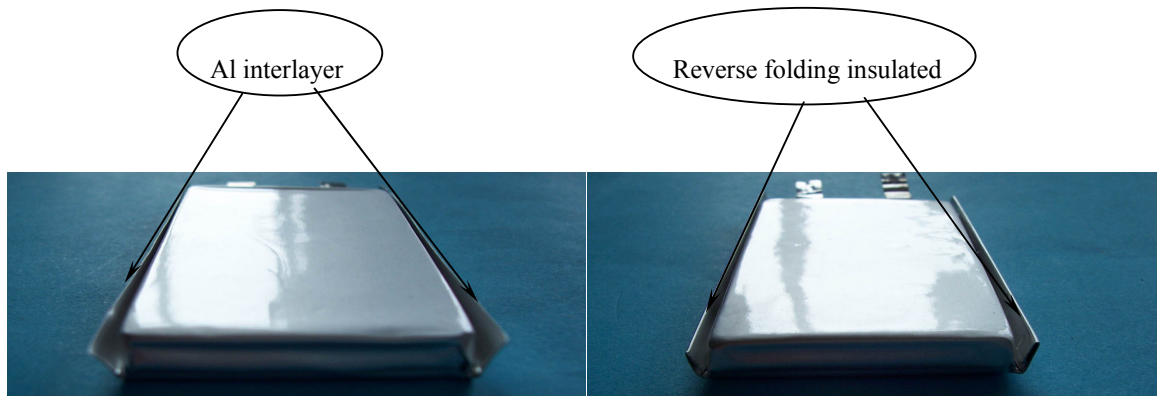

Pic 2: Single folding edge schematic of PL cells

Pic 3: Reverse folding edge schematic of PL cells

8.1.4 Tab: The cathode is Al tab and the anode is Cu tab.

- (1) The batteries' tabs are not so stubborn especially for aluminum tabs. Don't bend tabs.
- (2) The tab-tapes are used to isolate The anode /cathod tabs from Aluminum packing materials to prevent short-circuit, so prohibit manicuring of the tab-tapes.

8.1.5 Mechanical shock:

- (1) Don't fall, hit, bent the batteries' body.
- (2) Don't knock on by sinker or trample the batteries.
- (3) Don't sling the batteries.

8.1.6 Short-circuit: Short-circuit is strictly prohibited. It should damage batteries badly.

- (1) Don't connect the anode and cathod of the batteries to avoid short-circuit.
- (2) Prohibit short-circuit of the anode (or cathode) and aluminum layer of Aluminum packing materials.

8.2 Standard Test Environment for polymer LiFePO4 batteries:

Environment temperature: $20 \pm 5^\circ\text{C}$ Humidity: 45-85%

8.3 Cautions of charge & discharge:

8.3.1 Charge:

Charging current should be lower than values that recommend below. Higher current and voltage charging may cause damage to cell electrical, mechanical, safety Performance and could lead heat generation or leakage.

- (1) Batteries charger should charging with constant current and constant voltage mode;
- (2) Charging current should be lower than (or equal to) $1C_5A$; ;
- (3) Temperature $0\sim 45^{\circ}C$ is preferred when charging;
- (4) Charging voltage must be lower than 3.95V.

8.3.2 Discharge:

- (1) Discharging current must be lower than (or equal to) $2.0C_5A$;
- (2) Temperature $-10\sim 60^{\circ}C$ is preferred when discharging;
- (3) Discharging voltage must not be lower than 2.4V.

8.3.3 Over-discharge:

It should be noted that the cell would be at an over-discharge state by its self-discharge. In order to prevent over-discharge, the cell shall be charged periodically to keeping voltage between 3.2V-3.4V. Over-discharge may cause loss of cell Performance. It should be noted that the cell would not discharge till voltage lower than 2.0V.

8.4 Storage of polymer LiFePO4 batteries:

The battery should be stored with 40-60% charge state.

The environment of long-time storage:

Temperature: $20\pm 5^{\circ}C$;

Humidity: 45-85%;

Batteries were 40~60% charged.

The battery had better charge a time per three month during its storage for avoiding over discharge.

Please charge the battery with constant current $0.5C_5A$ for 1 hour once every three month when in storage so that it has some storage of charge for properly using.

Charge and discharge afresh to active and renew battery energy after storage above 1 year.

8.5 Transportation of polymer LiFePO4 batteries:

The batteries should transportation with 10~50% charged states.

8.6 Others:

Please note cautions below to prevent cells' leakage, heat generation and explosion.

- (1) Prohibit disassembling cells;
- (2) Prohibit immerse cells into liquid such as water or seawater;
- (3) Prohibit dumping the battery into fire;
- (4) Prohibit soldering directly the battery.
- (5) Prohibit charging the battery near fire or in the hot circumstance.
- (6) Prohibit placing the battery in a microwave oven or pressurized container.
- (7) Prohibit use or store the battery where is exposed to extremely hot, such as under window of a car in direct sunlight in a hot day. Otherwise, the battery may be overheated. This can also reduce battery Performance and/or shorten service life.
- (8) If the battery leaks and electrolyte gets in your eyes, do not rub them. Instead, rinse them with clean running water and immediately seek medical attention. If left as is, electrolyte can cause eye injury.
- (9) Prohibit using the battery if it gives off an odor, generates heat, becomes discolored or deformed, or appears abnormal in any way. If the battery is in use or being recharged, remove it from the device or charger immediately and discontinue use. If the battery leaks or gives off an odor, move it away from a fire source to avoid fire or explosion.

9. Cell packing and Fixing:

9.1 Notice of Designing Battery Pack:

Battery pack should have sufficient strength and battery should be protected from mechanical shock. No sharp edge components should be inside the pack contain the battery.

9.2 PCM design

The overcharge threshold voltage should not be exceed 3.95V.

The over-discharge threshold voltage should not be lower than 2.2V.

The PCM should have short protection function built inside.

9.3 Cell connection:

Ultrasonic welding or spot welding is recommended to connect battery with PCM or other parts.
If apply manual solder method to connect tab with PCM, the notice below is very important to ensure battery Performance.

- (1) The electric iron should be temperature controlled and ESD safe;
- (2) Soldering temperature should not exceed 350°C;
- (3) Soldering time should not be longer than 3s, keep battery tab cold down before next soldering;
- (4) Soldering times should not exceed 5 times;
- (5) Soldering spot location should be away from the tab film to ensure the sealing of the tab film.
- (6) The soldering spot should be smooth and there should be no acumination.

9.4 Cell fixing: The battery should be fixed to the battery pack by its large surface area. No cell movement in the battery pack should be allowed.

9.5 Cells replacement: The cell replacement should be done by professional people.

10. Schematic of Battery:

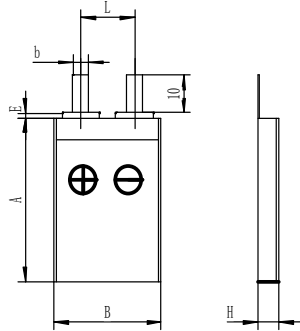

✓ Cell or adding Ni tabs

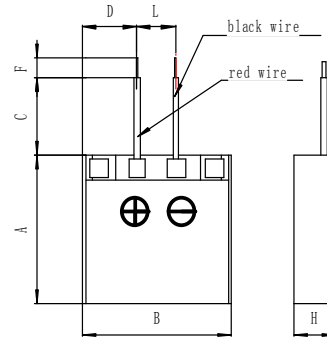

□ Cell adding PCM, wire

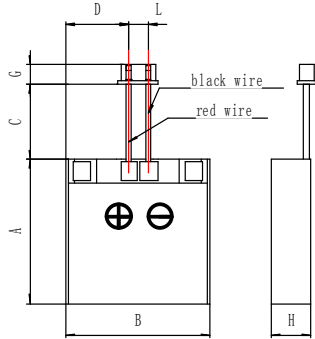

□ Cell adding PCM, plug

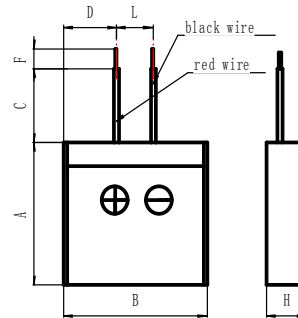

□ Cell adding wire

Parameter:

Sign	Item	MAX (mm)	Remark	Sign	Item	MAX (mm)	Remark
A	Length	46.5		L	Space between Tabs	17.2	
B	Width	41.0		b	Tab Width	5	
H	Thickness	10.2			PCM	/	